

天能帅福得能源股份有限公司
TIANNENG SAFT ENERGY JOINT STOCK COMPANY

产品规格书
Specification

款型名称 Name: 黑牛三号

型号规格 Model: 48V15Ah

制定(Prepared by): _____ 日期 Date: _____

审核(Checked by): _____ 日期 Date: _____

批准(Approved by): _____ 日期 Date: _____

地址: 浙江省长兴县雉城镇柏家浜 (画溪工业园)

ADD: Huaxi Industrial Zone, Changxing County, Zhejiang, China.

电话: Tel : +86-572-6216111 传真: Fax: +86-572-6216158

邮编: P.C.: 313100 网址: <http://www.tn-ny.com>

更改记录 Revision history			
编号 No.	日期 Date	版本 Revision	备注 Remark
1		A0	

1、概述 Overview

1.1 本规格书适用于天能帅福得能源股份有限公司制作的电动自行车用锂离子电池。

The specification applies to the Li-ion rechargeable battery for e-bike produced by TIANNENG SAFT ENERGY JOINT STOCK COMPANY.

1.2 本电池属环保电池，无化学汞和镉等成份。

This battery is environment-friendly with no Hg or Cd.

2、产品测试要求及标准 Test requirement and standard

2.1 环境要求 Environmental requirement

除非另有规定，本规格书中各项试验应在标准大气条件下进行：温度：23℃~27℃；相对湿度：45%~85%；

Unless otherwise specified, all tests in this specification shall be performed under standard atmospheric conditions: temperature: 23℃~27℃； relative humidity: 45%~85%；

大气压力：86 kPa~106 kPa

Atmospheric pressure: 86 kPa~106 kPa

2.2 产品参考标准 Reference

GB 及 CE 相关标准

GB and CE

3. 基本特性 General features

3.1、常规特性 Normal performance

测试项目 Test item	单位 Unit	规格 Specification	备注 Remarks
额定容量 Rated capacity	Ah	15	3A (0.2C) 充电, 7.5A(0.5C)放电 3A(0.2C)charge and7.5A(0.5C)discharge
标称电压 Nominal voltage	V	48	
内阻 Internal resistance	mΩ	≤250	标准充电后搁置 1~4h, 测量电池交流内阻 Rest for 1-4h after standard charge,test the AC internal resistance of the battery
大约重量 Weight	kg	4.3	
电池组外形尺寸 Dimension	mm	252×145×72	最大 Maximum
外观 Appearance		无变形、无爆裂、无漏液 No distortion,explosion or leakage	目测 Visual inspection
循环寿命 Cycle life		≥600 (60%)	标准充电, 搁置 10min, 7.5A 放电至 36.4V Rest for 10min after standard charge, discharge at 7.5 to 36.4V

储存条件 Storage conditions		-10℃~35℃, 65%±20%RH	每3个月充电一次 Charge every 3 months
----------------------------	--	------------------------	-----------------------------------

3.2、充电特性 Charge performance

测试项目 Test item	单位 Unit	规格 Specification	备注 Remarks
充电方式 Charge mode		CC/CV	锂电专用充电器 Special charger for Lithium-ion battery
充电电流 Charge current	A	3	标准(0.2C) Standard(0.2C)
最大充电电流 Max charge current	A	4.5	标准(0.3C) Standard(0.3C)
充电截止电压 Charge cut-off voltage	V	54.6	标准(4.2V/cell) Standard(4.2V/cell)
充电截止电流 Charge cut-off current	mA	300	标准(0.02C) Standard(0.02C)
充电时间 Charge time	h	5~8	推荐 Recommendation
环境温度 Ambient temperature	℃	0~35	此温度条件为最佳推荐值，实际可满足0~45℃条件下充电 This range is the recommended value, it can actually be charged at 0~45℃

3.3、放电特性 Discharge performance

测试项目 Test item	单位 Unit	规格 Specification	备注 Remarks
放电电流 Discharge current	A	7.5	标准(0.5C) Standard(0.5C)
最大持续放电电流 Maximum continuous discharge current	A	≤15	标准(1C) Standard(1C)
峰值电流 Peak current	A	22.5	标准(1.5C, 持续时间≤5S) Standard(1.5C/5S)
放电截止电压 Discharge cut-off voltage	V	36.4	标准(2.8V/cell) Standard(2.8V/cell)
环境温度 Ambient temperature	℃	-10℃ ~ 45℃	此温度条件为最佳推荐值，实际可满足-20~55℃条件下放电 This range is the recommended value, it can actually be discharged at -20~55℃

3.4、电气性能 Electrical performance

测试项目 Test item	单位 Unit	规格 Specification	备注 Remarks
低温性能 (-20℃) Low-temperature performance	Min	≥42 (70%)	标准充电后, -20±2℃搁置 16h, 15A 放电至 36.4V After standard charge, rest for 16h at -20±2℃, discharge at 15A to 36.4V
高温性能 (55℃) High-temperature performance	Min	≥54 (90%)	标准充电后, 55±2℃搁置 5h, 15A 放电至 36.4V After standard charge, rest for 5h at 55±2℃, discharge at 15A to 36.4V
低气压 Low air pressure		不泄露、不起火、 不爆炸	标准充电后, 在气压不高于 11.6KPa 下保持 6h After standard charge, keep for 6h at air pressure of less than 11.6KPa
荷电保持 Capacity retention 荷电恢复 Capability resume	Min	≥96 (80%) ≥108 (90%)	标准充电后, 开路搁置 28 天, 7.5A 放电至 36.4V After standard charge, rest for 28 days at open circuit, discharge to 36.4V at 7.5A 放电后标准充电, 7.5A 放电至 36.4V (允许循环 3 次) After standard charge, discharge to 36.4V at 6A (allow 3 cycles)
过充电保护 Overcharge protection		不泄露、不起火、 不爆炸, 正常工作; No leakage, fire or explosion, and work normally;	标准充电后, 连接在直流电源上进行充电。测试电压设定 72V (1.5 倍标称电压), 电流设定为 15A (2I ₂), 持续充电 24h, 目检电池组外观。 After standard charge, connect it to a DC power supply. Set the test voltage at 72V (1.5 times of nominal voltage) and test current at 15A (2I ₂) for 24h, and check the appearance of battery pack visually.
过放电保护 Over discharge protection		不泄露、不起火、 不爆炸, 正常工作; No leakage, fire or explosion, and work normally;	标准充电后, 以 7.5A (I ₂) 电流放电至 36.4V, 之后再以 1.5A (0.2I ₂) 电流恒流放电 24h, 目检电池组外观。 After standard charge, discharge at 6A (I ₂) to 36.4V, then discharge at constant current for 24h and check the appearance of battery pack visually.
短路保护 Short-circuit protection		不泄露、不起火、 不爆炸, 正常工作; No leakage, fire or explosion, and work normally;	标准充电后, 用 80mΩ±20 mΩ 外线路分别对充电端和放电端的正负极短路 0.5h, 目检电池组外观。 After standard charge, make short-circuit with external circuit of 80mΩ±20 mΩ to both charge end and discharge end for 0.5h separately. Check the appearance of battery pack visually

4、保护板参数 (BMS parameter)

序号 No.	检测项目 Item	最小 Min.	典型 Nominal	最大 Max.	单位 Unit
1	充电电压 Charge voltage	54.34	55.25	55.51	V
2	充电电流 Charge current		3		A
3	放电电流 Discharge current			20	A
4	单节过充检测电压 Overcharge protection voltage	4.18	4.25	4.27	V
5	过充恢复电压 Overcharge release voltage	4.05	4.1	4.15	V
6	单节过放检测电压 Over discharge protection voltage	2.76	2.8	2.85	V
7	过放恢复电压 Over discharge release voltage	2.95	3	3.05	V
8	放电过流保护 Over-current discharge protection	35	42	55	A
9	放电过流保护延时 Over-current protection delay	300	400	500	mS
10	短路/过流保护恢复 Short/over current protection release	短路//过流保护后移除负载自动恢复 Recover automatically by removing the load after short/over current protection			
11	过放保护恢复 Over discharge protection release	充电 charge			
12	静态电流 Current consumption		30	50	uA
13	工作温度范围 Operating temperature	-20	+25	+65	°C
14	保存温度范围 Storage temperature	-20	+25	+30	°C
15	保存湿度 Storage humidity(no water-drop)			70%	RH

5、产品图纸 Drawing

5.1 外形图 Outline drawing

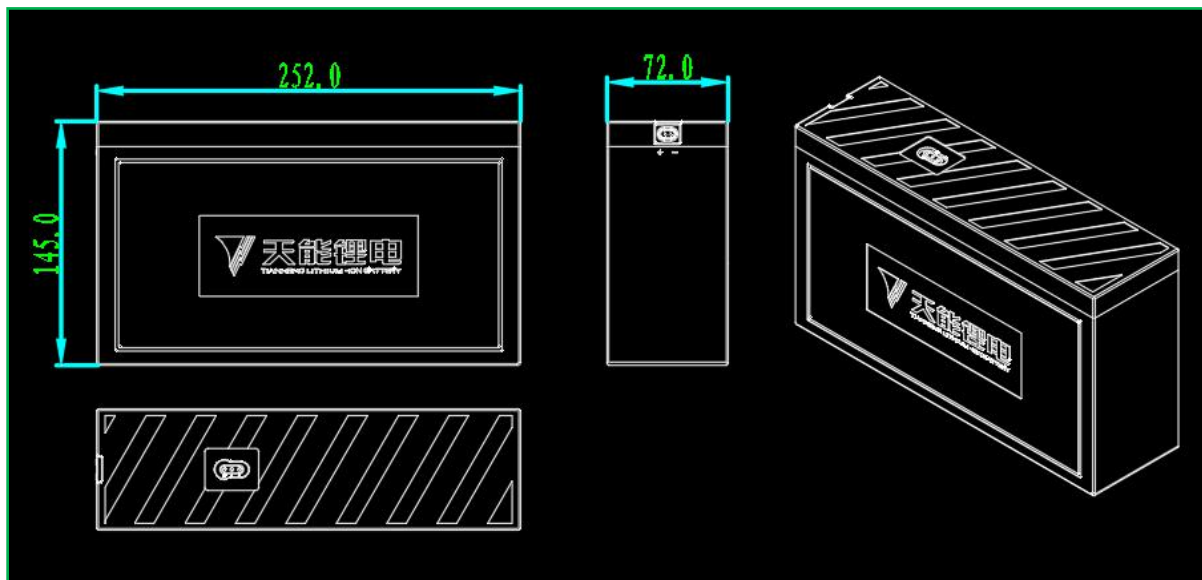

5.2 端口定义 Port

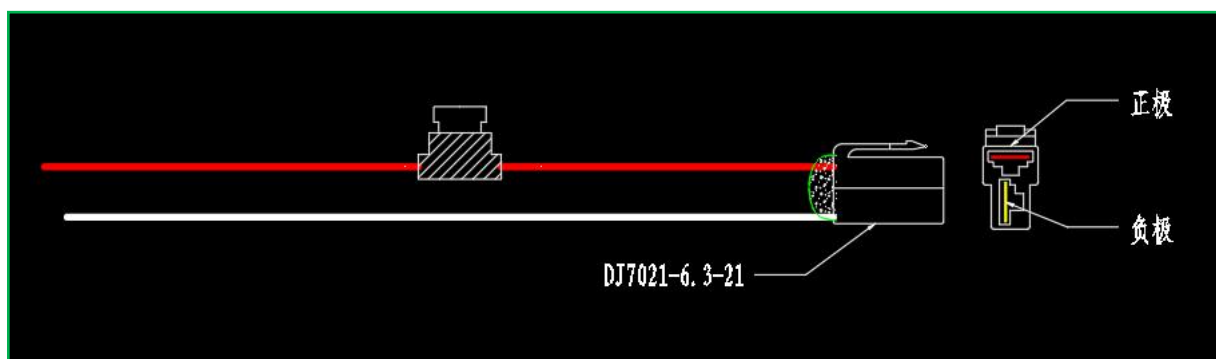

5.3 接线图 Circuit



5.4 标识图 Mark



容量标贴



闪电标识

5.5 包装图 Package

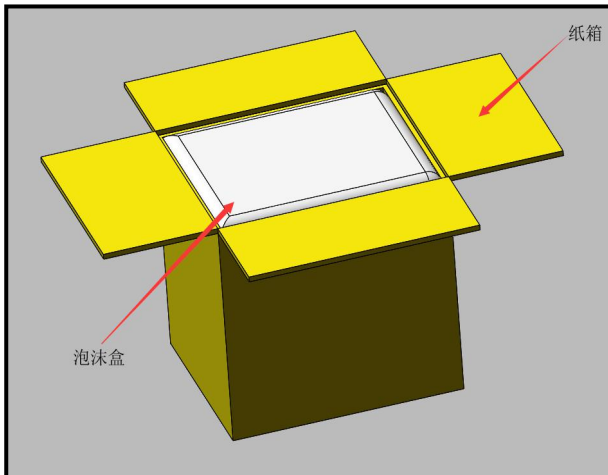

6、注意事项 WARNING

1、若长期（一周以上）不使用车辆，请将电池与整车断开连接，并保证每三个月充电一次，让电池在最佳储存电量储存。

When the battery is not in use for more than one week, please disconnect the battery from the vehicle and perform a full charge at least one time every 3 months to keep the battery being stored with optimal capacity.

2、请将电池在推荐的环境下使用和长期储存，以保证电池正常寿命。

The battery should only be used and stored for long term under recommended environment to ensure the service life.

3、在日常使用中，请尽量在电池电量不低于 20%时及时充电，可延长电池使用寿命。

In order to extend the lifetime of the battery, it is optimal to charge the battery before the charge level

falls below 20% capacity.

4、为保证电池充电安全，严禁将电池在 0℃ 以下环境充电。

To ensure the safety of charging, it is strictly forbidden to charge the battery below 0°C.

5、使用原厂配套锂电池专用充电器。

Please charge with the original charger for Lithium batteries.

6、不要对电池进行反充电或者将电池短路。

Do not reversely charge or short-circuit the battery.

7、不要滥用电池，请确认电池在规定的电压、电流范围内进行充放电。

Do not abuse batteries, please make sure that the battery is charged and discharged within the required range of voltage and current.

8、不要燃烧或毁坏电池，可能导致有毒气体释放或爆炸。

Do not incinerate or mutilate batteries, or it may cause the emission of toxic gases or explosion.

9、不要对电池进行直接焊接、拆解、改装。

Neither solder the battery directly, nor disassemble or refit it.

10、不要让电池处于不利环境中，比如极端的温度，深度循环，或者经常过充/过放电。

Do not place batteries in adverse conditions, such as extreme temperature, deep cycling or excessive overcharge/over-discharge.

11、将电池贮存在阴凉干燥处。

Store batteries in a dry and cool place.

12、不要将我公司电池与其他品牌的电池或者不同种类的电池，比如碱性锌电池混用。

Do not mix our batteries with other battery brands or batteries of a different chemistry, such as alkaline zinc battery.

13、不要将新旧电池混用。

Do not mix new batteries with used batteries.

14、如果出现噪音，温度异常，异味或者漏液，请停止使用。

In case of any noise, excessive temperature, peculiar smell or leakage, please stop use.

15、如果电池发烫，请勿触摸，直至冷却。

When the battery is very hot, please do not touch or handle it until it cools down.

16、取用电池组时，严禁直接拉拽导线。

When using the battery pack, it is strictly forbidden to pull the cable directly.

17、严禁将电池置于酸性、碱性、带盐物液体中，避免电池淋雨、泡水。

Do not put the battery in acid, alkaline or salty liquids, and keep the battery away from rain and water.

18、不要尝试分离，挤压，撞击电池，电池会发热或起火，电池中的碱液对皮肤和眼睛有害。

Do not attempt to separate, extrude or strike batteries. Heat may be generated or fire may result. The alkaline electrolyte in battery will be harmful to eyes and skin.

19、要使电池远离儿童，如发现吞食，立即联系医生。

Keep batteries away from children. If swallowed, contact a physician at once.

20、如果将电池用于其他设备，请与供应商联系确认产品适用性。至少应该咨询电池的大电流、快速充电、特殊应用的问题。

If the battery is used on other instruments, please contact with your manufacturer for confirmation. At least consult its maximum current, fast charge, special application, etc.

7、产品责任书 **Letter of responsibility for the product**

消费者必须严格遵守本规格书的要求使用电池，由于误用会引起电池过热，发生火灾或爆炸，对于没有按照规格书进行操作所造成的任何意外事故，天能帅福得能源股份有限公司不负任何责任。

All users should use our battery in strict accordance with this specification. Misuse of the battery may cause overheating, resulting in fire or explosion. TIANNENG SAFT ENERGY JOINT STOCK COMPANY bears no responsibility for any accident caused by failure to use the battery in accordance with this specification.