

天能帅福得能源股份有限公司
TIANNENG SAFT ENERGY JOINT STOCK COMPANY

产 品 规 格 书

Product Specification

型 号: MODEL NO.: TNL-13ITR-16

48V16Ah

制定(PREPARED BY): _____ 日期 DATE: _____

审核(CHECKED BY): _____ 日期 DATE: _____

批准(APPROVED BY): _____ 日期 DATE: _____

地址: 浙江省长兴县雉城镇柏家浜 (画溪工业园)

ADD: Huaxi Industrial Zone, Changxing County, Zhejiang, China.

电话: Tel : +86-572-6216111 传真: Fax: +86-572-6216158

邮编: P.C. : 313100 网址: <http://www.tn-ny.com>

更改记录 Revision History			
编号 No.	日期 Date	版本 Revision	备注 Remark
1		A0	



1、概述 Summarize

1.1 本规格书适用于天能帅福得能源股份有限公司制作的电动自行车用锂离子电池。

The specification is suitable to the Li-ion rechargeable battery for e-bike produced by TIANNENG SAFT ENERGY JOINT STOCK COMPANY

1.2 本电池属环保电池，无化学汞和镉等成份。

This battery is environment friendly, there are no Hg and Cd.

2、产品测试要求及标准 Test requirement and Standard

2.1 环境要求 The requirement of environment

除非另有规定，本规格书中各项试验应在标准大气条件下进行：温度：23℃~27℃；相对湿度：45%~85%；

Unless having additional statement, All tests in this specification will be done under standard atmosphere conditions: temperature: 23℃~27℃； relative humidity: 45%~85%；

大气压力：86 kPa~106 kPa

atmospheric pressure: 86 kPa~106 kPa

2.3 产品执行标准 The standard performed

公司企业标准； UL 及 CE 相关标准

Company' s standard, UL and CE

3. 基本特性 Basic characteristics

3.1、常规特性 Normal performance

测试项目 Test item	单位 Unit	规格 Specification	测试方法 Test method
额定容量 Rated Capacity	Ah	16	3.2A (0.2C) 充电, 8A (0.5C) 放电 0.2C charge and 0.5C discharge
最小容量 Min Capacity	Ah	≥额定容量的 95%	3.2A (0.2C) 充电, 8A (0.5C) 放电 3.2A (0.2C) charge and 8A (0.5C) discharge
标称电压 Nominal voltage	V	48	
开路电压(OCV) Open circuit Voltage	V	≥53.3(4.1v/cell)	标准充电后 1 个小时内测量 Within 1 hr after standard charge
内阻 Internal Resistance	mΩ	≤250	标准充电后搁置 1~4h, 测量电池交流内阻 Rest 1-4h after standard charge, test the AC internal resistance of the battery
大约重量 Weight(Approximately)	kg	6.0	
电池组外形尺寸 Dimension	mm	181×156×160	最大 Max
外观 Appearance		无变形、无爆裂、无漏液 No distortion, no explode, no leakage	目测 by eyeballing



储存要求 Storage performance		-5℃~30℃	
-----------------------------	--	---------	--

3.2、充电特性 Charge performance

测试项目 Test item	单位 Unit	规格 Specification	备注 Remarks
充电方式 Charge mode		CC/CV	标准 standard
充电电流 Charge current	A	3.2 (0.2c)	标准 standard
充电截止电压 Charge Cut-off Voltage	V	54.6	标准 standard
充电截止电流 Charge Cut-off current	mA	320 (0.02c)	标准 standard
充电时间 Charge time	h	5~8	标准 standard
环境温度 Ambience temperature	℃	0~35	

3.3、放电特性 Discharge performance

测试项目 Test item	单位 Unit	规格 Specification	备注 Remarks
放电电流 Discharge current	A	8	标准 standard
放电截止电压 Discharge Cut-off Voltage	V	36.4 (2.8V/CELL)	标准 standard
最大持续放电电流 Max continuous discharge current	A	≤20	
循环寿命 Cycle life	次	≥600 (60%)	标准充电, 搁置 10min, 8A 放电至 36.4V Rest 10min after standard charge, discharge at 8A to 36.4V
环境温度 Ambience temperature	℃	-20 ~ 45	

3.4、环境性能

测试项目 Test item	单位 Unit	规格 Specification	备注 Remarks
低温性能 (-10℃) Low-temperature performance	Min	≥90	标准充电后, -10±2℃搁置 16h, 0.5C 放电至 36.4V After standard charge, rest 16h at -10±2℃, discharge at 0.5C to 36.4V



高温性能 (55℃) High-temperature performance	Min	≥108	标准充电后, 55±2℃搁置 5h, 0.5C 放电至 36.4V After standard charge, rest 16h at 55±2℃, discharge at 0.5C to 36.4V
恒定湿热 Constant humidity and temperature		不漏液 No leakage	40±2℃, 相对湿度 90%~95%搁置 24h, 取出 20±2℃ 搁置 1h Rest 24h at 40±2℃ and relative humidity 90%~95%, take out and rest 1h at 20±2℃
低气压 Low air pressure		不漏液 No leakage	标准充电后, 在气压不高于 11.6KPa 下保持 6h After standard charge, keep 6h at air pressure less than 11.6KPa
荷电保持 capacity retention	Min	≥102	标准充电后, 开路搁置 28 天, 0.5C 放电至 36.4V After standard charge, rest 28days at open voltage, discharge to 36.4V at 0.2C
荷电恢复 capability resume		≥108	放电后标准充电, 0.5C 放电至 36.4V (允许循环 3 次) After standard charge, discharge to 36.4V at 0.5C (allow 3cycles)

4、单体电池安全性 safety

测试项目 Test	单位 Unit	技术要求 Specification	条件 Condition
过充电 Overcharge	N/A	不爆炸、不起火 No explosion and no fire	标准充电后, 以 3C 10V 充电 90min After standard charge, charge 90min at 3C 10V
外部短路 External Short Circuit	N/A	不爆炸、不起火 No explosion and no fire	标准充电后, 用内阻小于 50 mΩ 的线路短路电池 After standard charge, short circuit by line (internal resistance less than 50mΩ)
热滥用 heat misusing		不爆炸、不起火 No explosion and no fire	标准充电后, 以 5±2℃/min 升温至 130±2℃, 此温度下保持 30min After standard charge, Increase the temperature to 130±2℃ at 5±2℃/min and keep 30min
挤压测试 Extrusion	N/A	不爆炸、不起火 No explosion and no fire	标准充电后, 用 φ32mm 圆形截面挤压电池, 逐渐增加压力至 13 ± 1KN. After standard charge, extruding the battery with round section(φ 32mm) and increase the pressure to 13±1KN
自由跌落测试 Free falling(drop)	N/A	不爆炸、不起火 No explosion and no fire	标准充电后, 电池从 1m 高度自由跌落到水泥板面, X、Y、Z 三个方向各一次. After standard charge, the battery fall on cement floor freely from the least height of 1m in the direction of X,Y,Z, once for each direction(X,Y,Z).



5、保护板参数 (BMS parameter)

序号 No.	检测项目 Item	最小 Min.	典型 Nominal	最大 Max.	单位 Unit
1	充电电压 Max. charge voltage	--	54.6	--	V
2	充电电流 Max. charge current	--	5	--	A
3	放电电流 Max. discharge current	--	--	18	A
4	单节过充检测电压 overcharge protection voltage	4.175	4.2	4.225	V
5	过充恢复电压 overcharge release voltage	4.05	4.10	4.15	V
6	单节过放检测电压 over discharge protection voltage	2.75	2.80	2.85	V
7	放电过流保护 Discharge overcurrent protection	50	60	70	A
8	过放恢复电压 over discharge release voltage	2.9	3.00	3.10	V
9	短路/过流保护恢复 release method of Short/ over discharge/ over current protection	短路//过流保护后移除负载自动恢复 Remove the load			
10	过放保护恢复 release method of over discharge protection	充电 charge			
11	工作温度范围 Operating Temperature Range	-20	+25	+45	°C
12	保存温度范围 Storage temperature range	-20	+25	+30	°C



6、产品图纸 Product drawing

6.1 外形图 Outline Drawing

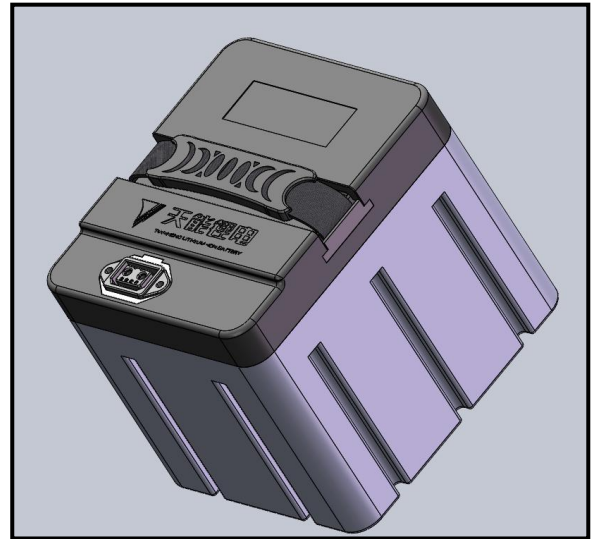
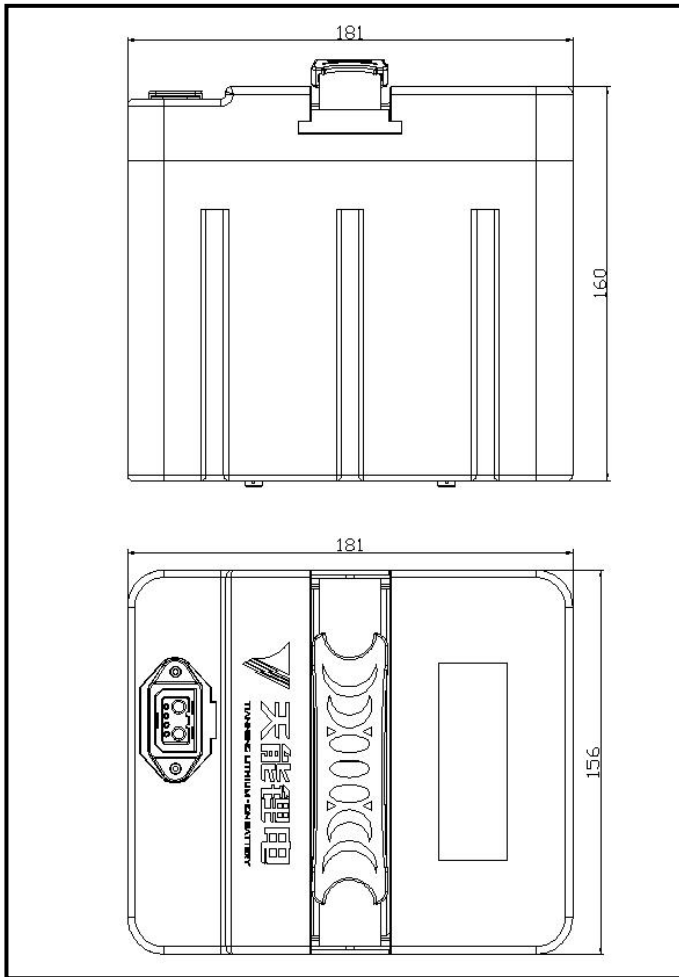

6.2 包装图 Package

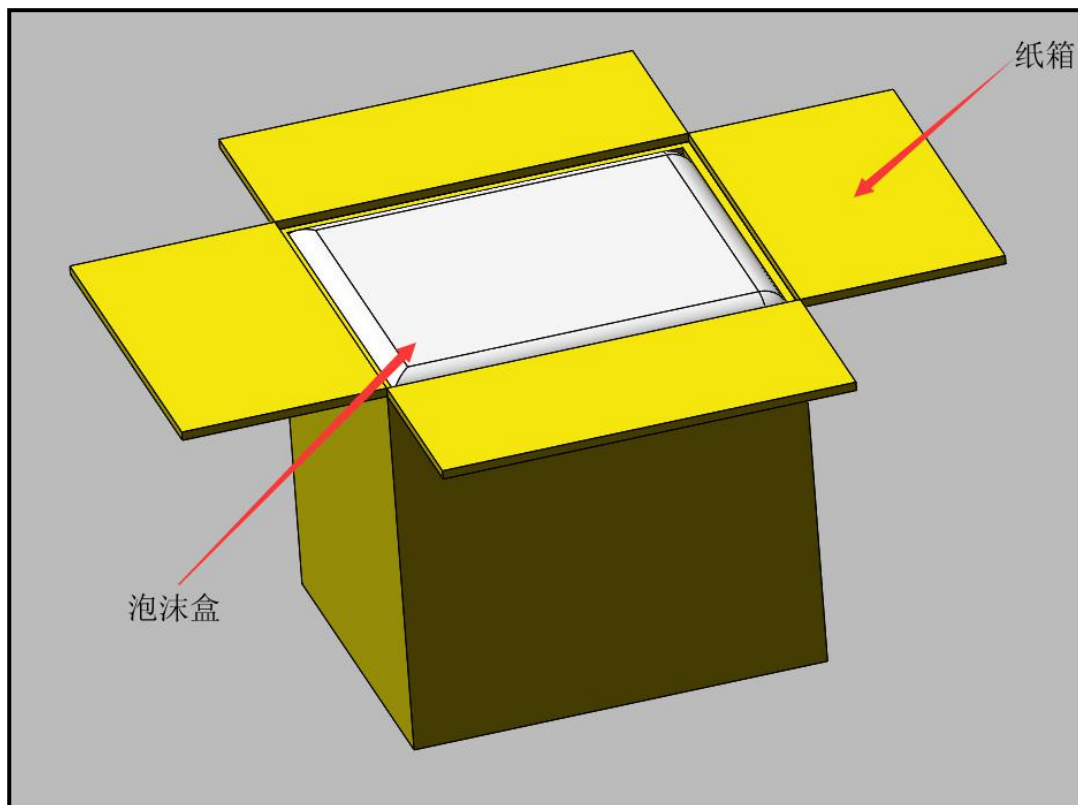

7、注意事项 PRECAUTIONS

- 1、电池长时间搁置期间，每隔 3 个月进行一次充放电

Not use the battery for long time, please charge and discharge every 3 months according to following method.

- 2、在使用新电池前，或者长期存放后第一次使用电池，在使用前请将电池充满电

When using a new battery for the first time or after long term storage, please fully charge the battery before use

- 3、充电方法请参考我们的技术手册

For charging methods, please refer to our technical handbook

- 4、使用 Li-ion 专用充电器

Use the correct charger for Li-ion batteries

- 5、不要对电池进行反充电

Do not reverse charge batteries

- 6、不要将电池短路，那可能永久的损坏电池

Do not short circuit batteries, permanent damage to batteries may result

- 7、不要燃烧或毁坏电池，可能导致有毒气体释放或爆炸



Do not incinerate or mutilate batteries, may burst or release toxic material

8、不要直接对电池进行焊接

Do not solder directly to cells or batteries

9、不要让电池处于不利环境中，比如极端的温度，深度循环，或者经常过充/过放电

Do not subject batteries to adverse condition such as extreme temperature, deep cycling and excessive overcharge/over-discharge.

10、将电池贮存在阴凉干燥处

Store batteries in a dry place

11、不要将我公司电池与其他品牌的电池或者不同种类的电池，比如碱性锌电池混用

Do not use our batteries together with other battery brands or batteries of a different chemistry such as alkaline and zinc carbon

12、不要将新旧电池混用，可能会导致过放电

Do not mix use new batteries with semi-used batteries, over-discharge may occurred

13、当把电池放入充电器中时，注意保证极性正确

When charging the battery with charger, ensure correct polarity

14、如果出现噪音，温度异常，或者漏液，请停止使用

If find any noise, excessive temperature or leakage, please stop use

15、如果电池发烫，请勿触摸，直至冷却

When the battery is very hot, please do not touch and handle it until it cool down

16、不要把电池（电池组）的外套去除

Do not remove the outer sleeve from a cell(or battery pack)

17、电池使用时发现功率下降，请关闭用电器开关以防止电池过放

When finding battery power down during use, please switch off the device to avoid over-discharge

18、当电池不使用时，请把它从装置上取下

When not using a battery, take out from the device

19、取下电池组时，用手抓住插头而不是拉线

Take out the battery by holding the connector itself and not by pulling its cord

20、电池使用后，如果电池发热，再次充电前，请在通风环境中冷却

After use, if the battery is hot, before recharging it, should cool the battery in a well-ventilated place.

21、不要将电池放入水中或海水中

Never put a battery into water or seawater

22、不要尝试分离，挤压，撞击电池，电池会发热或起火.电池中的碱液对皮肤和眼睛有害，而且会损伤衣服

Do not attempt to take batteries apart, extrusion or impact. Heat may be generated or fire may result. The alkaline electrolyte in battery will be harmful to eyes and skin, and it may damage clothing

23、要使电池远离儿童. 如发现吞食，立即联系医生

Keep away from children. If swallowed, contact a physician at once



8、产品责任书 products responsibility

消费者必须严格遵守本规格书的要求使用电池，由于误用会引起电池过热，发生火灾或爆炸，对于没有按照规格书进行操作所造成的任何意外事故，天能帅福得能源股份有限公司不负任何责任。

All users should use our battery according to this specification strictly. TIANNENG SAFT ENERGY JOINT STOCK COMPANY will not be responsible to battery's heat generation, fire, explode

